

ISSI	ZONE	REVISION	DESCRIPTION

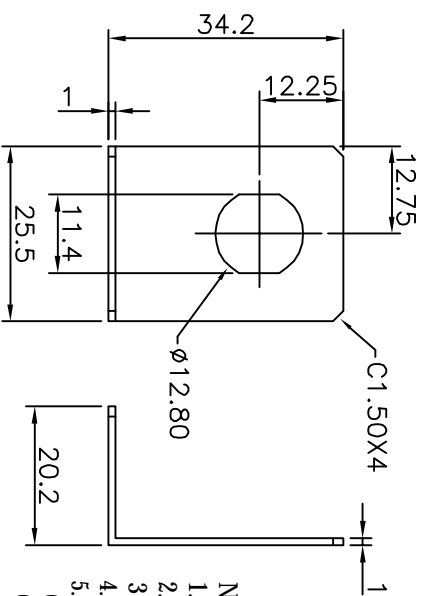
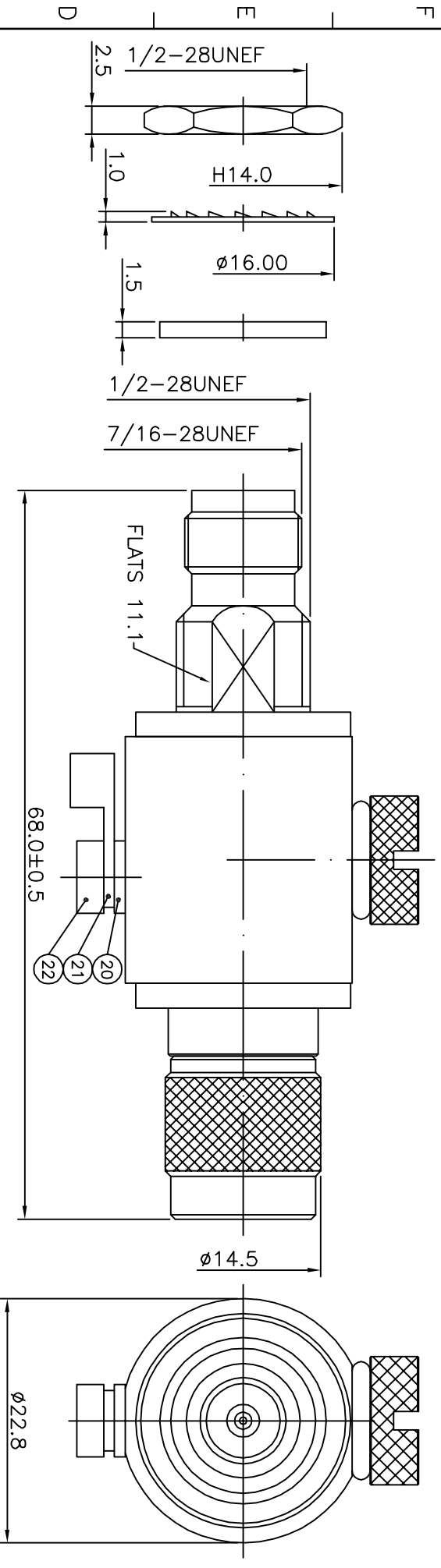

NOTE:  
 1. Impedance: 50Ω  
 2. Frequency Range : DC-6 GHz  
 3. V.S.W.R. : ≤ 1.5  
 4. Gas Tube DC Spark Over Voltage : 230V  
 5. Gas Tube Impulse Discharge Current (Wave 8/20 us) 10 Times  
 (5 Times Each Polarity) : 10KA

NO.	DESCRIPTION	MATERIAL	FINISH	Q'TY	DRAWN NO.
24	SLEEVE	SUS 304	NONE	1	M-0374
23	BRACE	AL.	NONE	1	O-0121
22	SCREW	BRASS	NICKEL	1	M-0248
21	WASHER	BRASS	NICKEL	1	M-0329
20	WASHER	BRASS	NICKEL	1	M-0330
19	SHELL	BRASS	NICKEL	1	A-0010
18	GASKET	SILICONE	RED	1	R-0007
17	WASHER	BRASS	NONE	1	G-0023
16	INSULATOR C	TEFLON	NONE	1	T-0502
15	CONTACT PIN B	BRASS	GOLD	1	C-0691
14	BODY C	BRASS	NICKEL	1	B-0854
13	BODY B	BRASS	NICKEL	1	B-0837
12	GAS TUBE	NONE	NONE	1	O-0089
11	GASKET	SILICONE	RED	1	R-0032
10	SLEEVE	BRASS	NICKEL	1	E-0048
9	NUT	BRASS	NICKEL	1	D-0066
8	GASKET	SILICONE	RED	2	R-0033
7	INSULATOR B	TEFLON	NONE	2	T-0403
6	CONTACT PIN A	BRASS	GOLD	1	C-0690
5	INSULATOR A	TEFLON	NONE	1	T-0501
4	BODY A	BRASS	NICKEL	1	B-0853
3	GASKET	RUBBER	BLACK	1	R-0020
2	WASHER	BRASS	NICKEL	1	G-0016
1	NUT	BRASS	NICKEL	1	D-0003

TOLERANCES  
 DIMENSIONS ARE IN MILLIMETER  
 UNLESS OTHERWISE SPECIFIED

.X  
 .XX  
 .XXX  
 ANGLES  
 ±0.2  
 ±0.1  
 ±0.05  
 ±5°

TITLE	TNC JACK REVERSE TO TNC PLUG REVERSE LIGHTNING PROTECTOR
PART NO.	95-38-5-50Q
DRAWN NO.	95-0052

APPROVED	DATE	 <b>SOCAA CORP., LTD.</b> (Solution Of Connector & Antenna)
CHECKED	DATE	
DRAWN	DATE	

1 2 3 4 5 6 7 8